

Primary SPRT 670 Family

- Useable Range -200°C to 670 °C
- 25.5 Ohm SPRT
- Outstanding Performance

The 670SQ is our latest thermometer, to be specifically designed to give optimum performance up to the aluminium point. Its construction permits the four internal platinum lead wires to expand and contract in the same manner as those of silver-point thermometers. The all-quartz construction of the support members gives the most stable performance with minimal drift, and a unique platinum radiation shield prevents heat radiating up the inside of the sheath.

The temperature range and design of this new unit means that we can now offer 25.5 Ohm (Ro) and 100 Ohm (Ro). The construction, including the coiled sensing element, heat-shunt baffles and light scattering barriers, creates a thermometer of unsurpassed stability.

Because the 670SQ goes beyond the temperature range of oxide growth to the level at which the oxide dissociates, the 670 is filled with a unique argon/oxygen mixture. A 2.5 metre length of low thermal EMF, high temperature, screened cable is connected in the handle, via a strain-relieving transition, to the all pure platinum construction of the thermometer.

Gold-plated U-shaped terminals complete the cable construction, and the 670SQ is delivered in an elegant soft lined carry-case of our own design. A 670SQ is supplied only after a stabilising process which is complete when the reproducibility of R_{TPW} is within 0.0005°C after excursions to the extremes of its temperature range. Values of R_{TPW} and W_{ga} are routinely provided with the 670SQ.

The 670SQ can be supplied with R_{TPW} and W_{ga} only or with full UKAS calibration. "With calibration" means that you will get an Internationally accepted Fixed Point calibration. For best accuracy, recommended maximum measuring currents for the 670SQ are 1mA for the 25.5Ω (Ro) and 0.5mA for the 100Ω (Ro).

A comprehensive handbook and tutorial will help you get the very best performance and stability from your 670SQ.

The 670SQ 650mm long is our recommended SPRT offering ultra stability, and has superior vibration, shock, immersion and self heating characteristics. From the success of the original Model 670 SPRTs we have introduced new models into the 670 range offering metal sheathed and low temperature models.



Super Stable Standard Platinum Resistance Thermometer

Models	670SQ, 670SH, 670SL
Measuring Range	-200°C to 670°C
Nominal Resistance	25.5Ω Ro or 100Ω Ro
Resistance Ratio	$W_{ga} > 1.11807$ as required by ITS-90
Sensitivity	0.1Ω / °C (25.5Ω) 0.4Ω / °C (100Ω)
Long term drift	from 0.001°C / year depending on use

How to Order

Model 670SQ, 670SH, 670SL / 25.5 or
Model 670SQ, 670SH / 100

State "with UKAS Calibration" or "without UKAS Calibration".

Whilst metal sheathed thermometers appear more robust than the quartz glass models it should be noted that ALL SPRTs are fragile devices and must be handled with care. Quartz glass thermometers have the advantage that the internal components are visible and can be inspected and continue to be our recommended models.

The low temperature models have excellent immersion characteristics and a significant cost saving when compared to the higher temperature models.

Having selected the finest cells and apparatus select Isotech SPRTs, with over thirty years experience of manufacturing platinum resistance thermometers it is not surprising we have developed the finest standard thermometers.

Our preferred standards in our UKAS lab are the 670SQ for up to 660°C and the 96178/0.25 for use up to the silver point, 962°C.

Benefits to your laboratory, ultra stability, best SPRT vibration and shock resistance, best immersion characteristics, low self heating, longer life and less contamination.

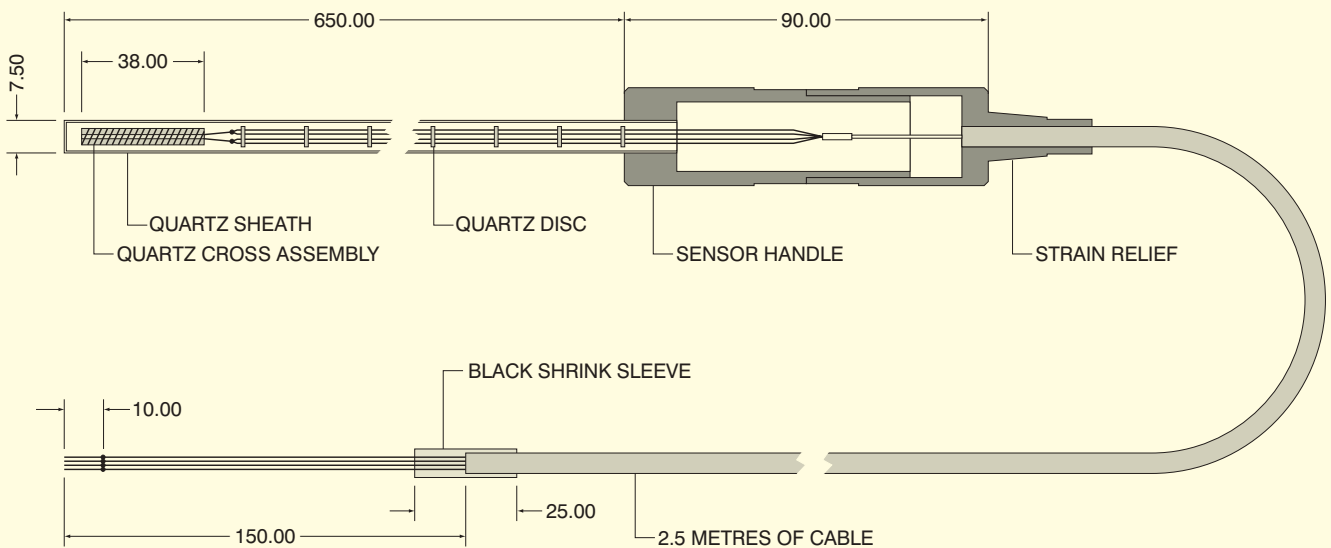

Model	Range (°C)	Ro (Ohms)	Sheath	Diameter	Length	Sensing Length	Comments
670SQ	-200 to 670	25.5	Quartz	7.5mm	650mm or 480mm	35mm	Recommended for wide range use in the Primary Laboratory
670SQ	-200 to 550	100	Quartz	7.5mm	650mm or 480mm	35mm	100 Ohm version
670SH	-80 to 670	25.5	Metal	6mm	650mm or 480mm	35mm	Metal sheathed high temperature model
670SH	-80 to 550	100	Metal	6mm	650mm or 480mm	35mm	100 Ohm version
670SL	-200 to 165	25.5	Metal	6mm	480mm	35mm	Metal sheathed low temperature model

SPRT Calibration with ITS-90 Fixed Points: Premium Service
ISOTECH UKAS Calibration Uncertainties (k=2)

Suitable only for Isotech 670SQ Models or other Primary Standard SPRTS of similar stability

Fixed Point	°C	Range 1	Range 2	Range 3	Range 4	Range 5	Range 6
Typical Uncertainties ±							
TP Argon ¹	-189.3442	0.5mK		0.5mK	0.5mK	0.5mK	0.5mK
TP Mercury	-38.8344	0.3mK	0.3mK	0.3mK	0.3mK	0.3mK	0.3mK
TP Water	0.01	0.1mK	0.1mK	0.1mK	0.1mK	0.1mK	0.1mK
MP Gallium	29.7646		0.2mK				
FP Indium	156.5985			1mK	1mK		
FP Tin	231.928				1mK	1mK	1mK
FP Zinc	419.527					1.2mK	1.2mK
FP Aluminium	660.323						2mK

Note 1: Alternatively in place of TP Argon the BP Nitrogen point can be used, the uncertainty increases to 5mK for Ranges 1, 3, 4 & 5 and 6mK for Range 6.

Note: TP = Triple Point MP = Melting Point
 FP = Freezing Point BP = Boiling Point

Note: The 100Ω 670 has a maximum temperature of 550°C and so cannot be UKAS certified over Range 6. Please contact Isotech if calibration is required above Zinc.

Table shows Premium Calibration Service, Standard Service is also available, see page 19.

