



-20 to 125°C

- Low Temperature Radiation Pyrometer Primary Source
- 50mm Diameter Cavity
- 0.995 Emissivity

The Hyperion R Portable Blackbody Calibration Source allows for calibration of non contact infrared thermometers over the temperature range -20°C to 125°C.

One application is the calibration of non-contact medical thermometers. With the sudden step increase in the demand to check and calibrate medical thermometers we have supplied many units for both portable and laboratory testing relating to the coronavirus outbreak.

It is suitable for use as a primary radiation source for infrared thermometers from sub zero to 125°C.

Laboratory performance and low uncertainty calibrations are ensured by the combination by high emissivity and excellent temperature uniformity.

The digital temperature controller allows the block temperature to be set to any value from -20°C to 125°C.

Traceability of the radiance temperature is established by a separate, built-in temperature indicator and included platinum resistance thermometer.

A three point traceable calibration certificate is included. UKAS calibration of the resistance thermometer is available, as is radiometric calibration.

Uniformity of the block is ensured by using distributed thermoelectric heat pumps with the benefit of solid state, vibration free cooling.

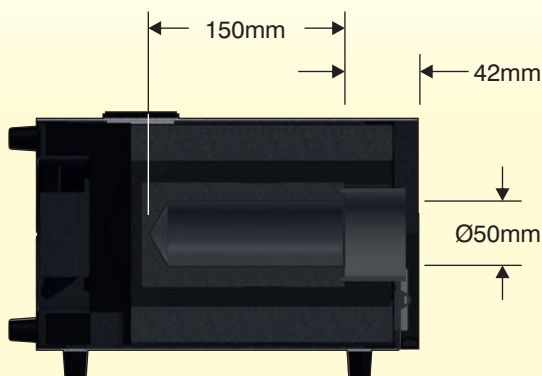

Hyperion R
Blackbody Dimensions

Blackbody Source Hyperion R



Model	982
Temperature Range	-20°C to 125°C* *In an ambient of 20°C, minimum temperature 40°C below ambient
Emissivity	Greater than 0.995
Stability	±0.1°C
Display Resolution	0.01°C to 0.1°C
Aperture Diameter	50mm
Cavity Depth	150mm
PC Interface	Included
Power	200 Watts typical
Voltage	Universal Input 80-264 V 50/60Hz
Dimensions	H 310mm W 265mm D 200mm
Weight	8.3kg
Options	
Orifice Plates 10, 20, 30, 40mm (Restricts Cavity Aperture)	812-01-06
Carrying Case	931-22-64

How To Order

Model 982 Hyperion R
Please state any special calibration requirement

Choose **Hyperion R** for:

- Superior Performance - isothermal cavity offers higher emissivity than flat plates
- Low Uncertainty Calibration Source for IR Thermometers and Thermal Imagers
- Calibration in the laboratory, on-site or in production

Gallium Fixed Point Cell

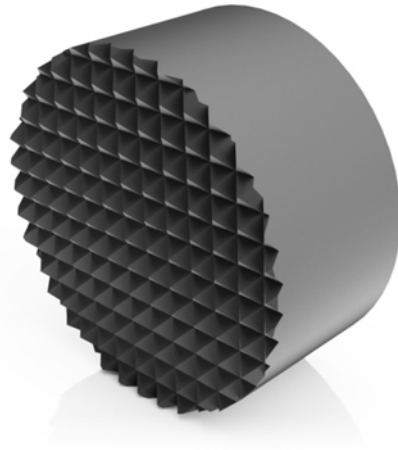

Heat Up / Cool Down

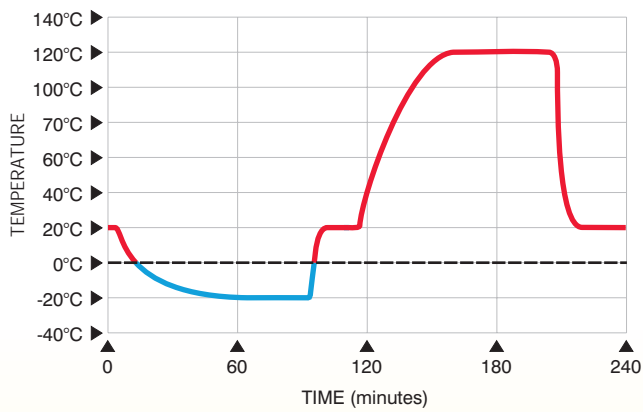

Following requests from researchers looking to improve the accuracy of infrared measurements, we have introduced a Gallium Fixed Point Cell, Model 982-05-01.

The cell contains high purity Gallium, 99.99999% (7N). It is placed into the Hyperion R cavity and heated until the metal melts at 29.7646°C.

As the Gallium melts, the temperature remains constant with the “melt plateau” providing a stable, precise constant reference temperature. After all the metal has melted, the cell can be simply frozen by lowering the Hyperion R temperature, no additional equipment is necessary.

