



## Model 6011C Automated 100 Amp Range Extender

*100 Amp Capability  
Self-Balancing  
10:1, 100:1, 1000:1 Ratios*

### General Description:

The 6011C is a precision DC Current Range Extender. Using innovative technological improvements to the direct current comparator, the linearity specification has been improved to less than 0.1 ppm over its entire range.

The 6011C can be used as a stand-alone unit for dividing high currents down to workable levels. The 6011C also includes, a built-in, 100A Reversing Switch. The system can be automated using a controller, a Model 6100A DC power Supply and DVM to measure the voltage across a standard resistor. Full-scale output current of the 6011C is 100 mA on all ranges.

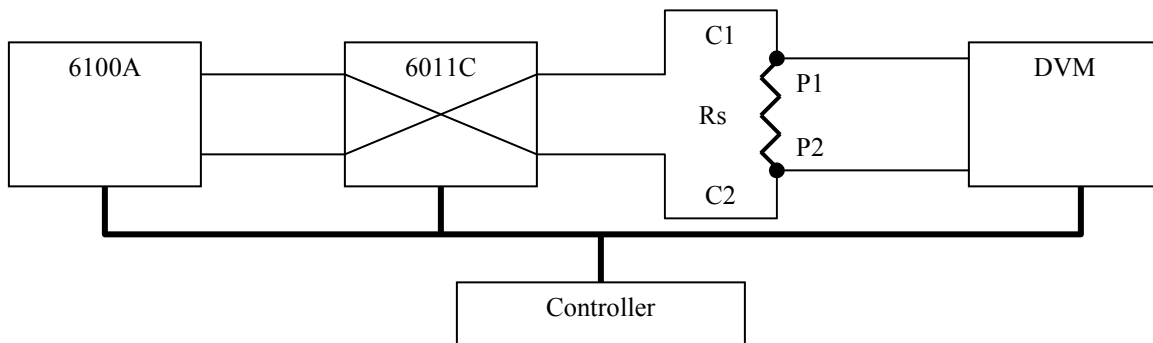

The 6011C Range Extender may also be used in conjunction with MI's Model 6010 Resistance Bridge and 6100A DC Power Supply. The Model 6010/6011C/6100A provides automated, accurate measurements from .0001 Ohm to 0.100 Ohm directly against a 1-Ohm primary standard automatically.

